

KEY FEATURES

- Special grade stainless steel bowl for maximum heat transfer and energy efficiency.
- All stainless steel outer surfaces for easy cleaning and durability.
- Complete with two bulk pasta baskets and five portion baskets and insert.
- Semi-automatic fill.
- Stackable, to minimize floor space requirements.
- 12 months parts & labour warranty.
- 10 year parts availability guarantee.
- Australian born & bred.



FRG-1P

MODELS



FRG-1P

FRG-1PL

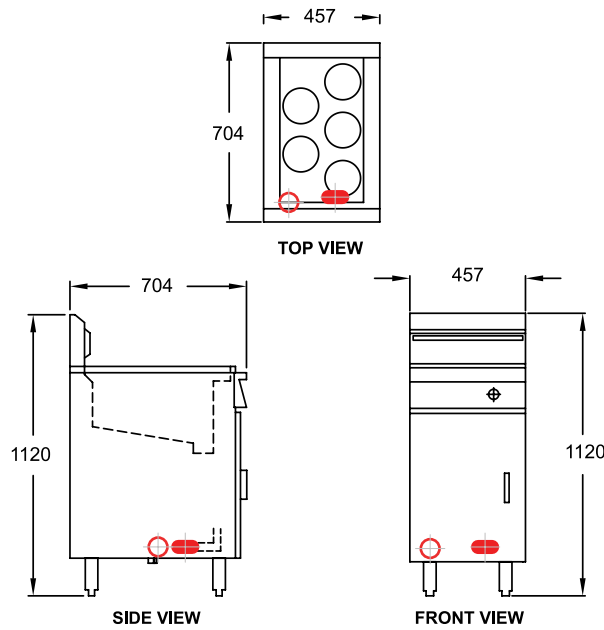
FRG-1P





MODEL: FRG-1P Specifications:	
Dimensions (WxDxH):	457 x 704 x 1120 mm
Working Height:	914 mm
Baskets:	5 standard portion & 2 stainless steel baskets
Packed:	0.4 m ³
Gas Connection:	19 mm BSP
Rating:	80 Mj
Weight:	90 kg
Water Connection:	13 mm BSP

 GAS INLET 3/4" BSP
 WATER INLET 1/2" BSP

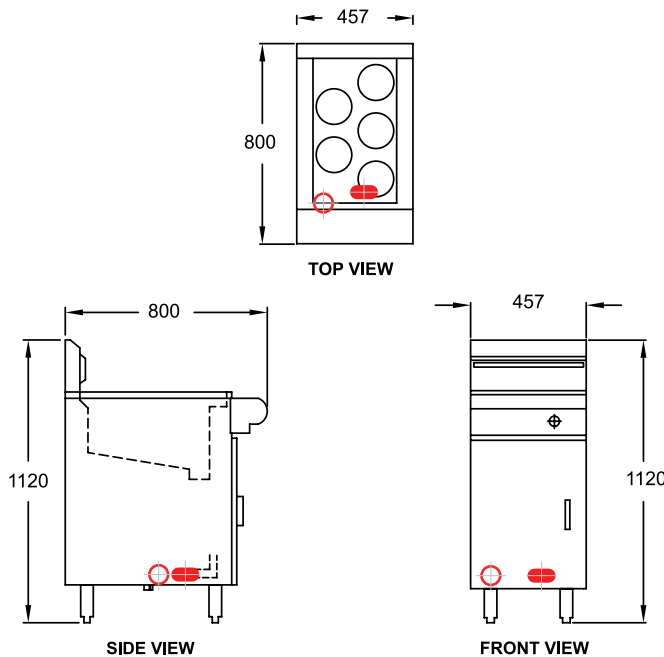
FRG-1PL



MODEL: FRG-1PL Specifications:	
Dimensions (WxDxH):	457 x 800 x 1120 mm
Working Height:	914 mm
Baskets:	5 standard portion & 2 stainless steel baskets
Packed:	0.4 m ³
Gas Connection:	19 mm BSP
Rating:	80 Mj
Weight:	90 kg
Water Connection:	13 mm BSP

 GAS INLET 3/4" BSP
 WATER INLET 1/2" BSP

Goldstein Eswood continually works on improving our products, so dimensions may change without notice. For any construction critical dimensions please check with us.